

IMPACT OF FINANCIAL TECHNOLOGY ON BANKING INDUSTRY IN INDIA - A CASE OF SELECT PRIVATE SECTOR BANKS IN HYDERABAD CITY - A SEM APPROACH

K. Naupal Reddy ¹ and Dr. M. Vidyasagar ²

¹ Research Scholar, Malla Reddy University-Hyderabad.
Senior Assistant Professor, Department of Management Studies,
Geethanjali College of Engineering and Technology-Hyderabad.
Email: naupal.mba@gcet.edu.in

² Professor and BBA-HOD, Malla Reddy University-Hyderabad.
Email: drmvidyasagar@mallareddyuniversity.ac.in

DOI: [10.5281/zenodo.11229830](https://doi.org/10.5281/zenodo.11229830)

Abstract

Purpose: This study utilises data collected from a case study of private sector banks in Hyderabad, India, to make inferences on the impact of monetary innovation on the Indian financial industry. The Role of Fintech services used by the Privat sector banks in Hyderabad and what are the challenges and opportunities in banking industry in India. **Design/Methodology/Approach:** The essential objective of this examination is to make determinations about the effect of monetary innovation on confidential banking in the Hyderabad region of the Indian territory of Telangana and the job that these advances play in the financial area by and large in India. I selected five private sector banks like Axis Bank, Yes Bank, IDBI First Bank, ICICI Bank and Bandan Bank. **Originality/Value:** Experts in the field of financial technology have taken notice of the recent explosion in Fintech services and developments, and they are now trying to determine how these changes will affect the banking industry. To decide how the fintech age has impacted the security of China's monetary framework, this exploration utilizes various insightful instruments. a monetary area comprised of organizations that improve the proficiency of monetary administrations through the utilization of innovation. Startups in the financial technology space often aim to disrupt established financial institutions and take on more software-dependent established firms. This study applies Least Squares regression (OLS) and Using MIDAS Model for secondary data. **Findings:** Through this paper, we expected to make sense of the capability of FinTech inside the financial area and the monetary business in general, enlightening FinTech as a tsunami of development in the monetary business that converged with cutting edge telecom and data innovation. The India stack project is another programme that has made a significant difference. An impressive 18 different FinTech solutions were implemented by banks. In terms of financial technology, AI was by far the most popular, with blockchain and machine learning following closely after.

Keywords: Fintech Applications, Private Banks, ADF Test, MIDAS Model.

JEL Codes: M18, M15, M96, M98.

1. INTRODUCTION

Monetary innovation, or fintech, is a substantial point of view on utilizing age to give new monetary merchandise and notable items that monetarily catch new shopper gatherings. The new financial technology industry is sprouting up thanks to digital giants that are partnering with or acting as intermediates for more traditional banks and financial institutions to handle crucial payments and markets. Controllers, traditional banks, NBFCs, clearing banks, buyers, charge specialist organizations, financier firms, resource the executives organizations, insurance agency, and, obviously, club are trying to destroy Fintech. A growing number of stakeholders are finding it to be the most appealing aspect. financial technology (FinTech) sports fan.

With the aid of fintech, financial institutions might become more efficient, customers could have access to a wider range of goods at lower rates, and the financial

landscape could undergo a fundamental shift. Keeping up with the underlying technical and entrepreneurial flux requires constant monitoring and evaluation of the fast and transformative changes brought about by FinTech. This article offers a concise overview of the industry, including its history, traits, and global and Indian driving forces. Financial technology companies must work to eliminate digital disparities and increase diverse and fair consumer engagement if they want to see their business ecosystems thrive. (www.rbi.org.in)

Structure of Fintech Industry

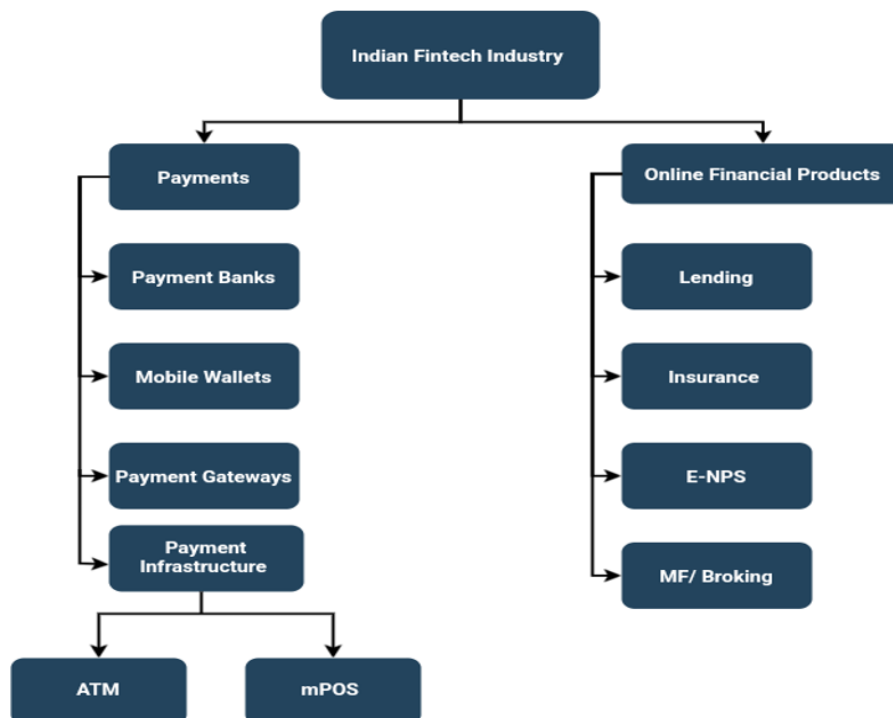

5 challenges in fintech for incumbents

Protecting sensitive information:

A sum of 1,862 information breaks happened in 2021, with a typical expense of \$4.24 million. Concerns about banking cybersecurity have never been higher, and this marks a new all-time high. Business owners should be aware that they stand to lose both face and money if they do not take precautions.

Observance of regulations:

Government rules are a major obstacle in the fintech business, which is already fraught with danger. The General Data Protection Regulation (GDPR), the Genetic, Local, and Broad Act (GLBA), the Wiretap Act, the Money Laundering Control Act, and countless more have mandated compliance for businesses.

Skill gap in technology:

When it comes to mobile banking, many financial institutions still rely on antiquated technologies or fail to innovate. Their applications aren't intuitive or user-friendly, therefore this is a major problem. There has been a noticeable change in emphasis recently towards improving the user experience, but there is still a long way to go.

Customising the service:

Using AI to learn about a customer's preferences is a common practice in personalisation. You should think about it since AI is now one of the most sought-after fintech development services.

Customer loyalty and satisfaction:

One of the biggest problems in fintech is keeping people interested. Income drops as a consequence of fewer users due to low retention. Giving users more of what they want might increase their likelihood of sticking around. One way to keep an eye on the user experience is to watch what your rivals are doing. You may learn which approaches work best for your business by seeing others in action.

Types of Fintech Apps found in the market today

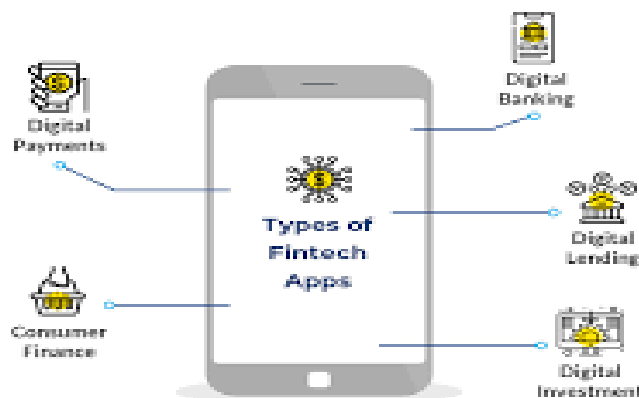

2. REVIEW OF LITERATURE

Srinivasan, K. & Raja Rajeswari (2021): Fintech drivers, the problems with conventional banking, and the impact of technology development are the topics this article aims to cover. Concerning fintech investment and disruption, the article also touches on such topics. Problems with investment management, client service, and rules and regulations are examples of financial technology issues.

Mehrotra, R. (2019): With the globalisation of markets and the expansion of financial sectors, more and more individuals are shifting away from using cash and towards using a cashless system, which is seeing steady growth. There is an urgent need for the cashless system in the modern world. The outcomes of initiatives to promote financial inclusion in India throughout the last few years have been inconsistent. Strong governmental and regulatory pressure has led to a huge expansion in access to bank accounts.

Upadhyay, V. (2020): By combining the terms "financial" and "technology," the name "FinTech" is created. Innovations in financial technology have the potential to revolutionise financial markets, institutions, and the creation of new business models, applications, procedures, and products for the purpose of providing financial services.

K. Vijaya, C. (2019): Financial technology, or Fintech, is defined in this article as tools and systems that facilitate monetary transactions, both inside and outside of traditional banking institutions. New ideas are popping up in the financial sector, and one of them

is fintech. Examining the opportunities and threats facing the fintech sector is the primary goal of this study.

Chugh, B. (2020): In this article, we will look at the topic of fintech regulation in India and try to find a solution. The article starts by taking a look at the many fintech initiatives that are aimed at the general public in India. In India, it recognises fourteen distinct kinds of fintech that target consumers. This typology of consumer-facing fintech operations in India is comprised of the fourteen kinds mentioned above.

Pant, S. K. (2021): Financial technology, in its most basic definition, alludes to the utilization of innovation in the arrangement of banking and monetary administrations to both individual and corporate clients. India is home to three of the world's most promising financial technology businesses, and the industry is booming worldwide. Fintech companies use the cloud, blockchain, cryptocurrency, artificial intelligence, data analytics, machine learning, big data, robotics, and robotics to offer their goods. The development of domestic and international broadband connection by telecommunications companies provided the groundwork for the expansion of the financial technology industry.

Guild, J. (2017): Tens of billions of dollars' worth of venture money has been flowing into the financial technology (Fintech) sector in recent years. Computerized cash move administrations in India and Kenya and distributed loaning stages in China are instances of fintech advancements. Hundreds of millions of individuals who do not have access to financial services will soon get them, thanks to these services and supplementary government policies and regulatory frameworks that could revolutionise the financial sector.

Kang, J. (2018): When it comes to Fintech, protecting the privacy and security of consumer information is a top priority. Robust authentication systems may prevent data intrusions thanks to technical procedures. Traditional financial institutions have created a niche for themselves, but fintech is quickly filling it and providing far higher levels of customer satisfaction because to its unique benefits.

Ray, T. (2020): Numerous studies and articles on Fintech and its impact on India's banking sector attest to the expanding body of knowledge in this area. Furthermore, it is very crucial to note the link between the financial efficiency of FinTech and the COVID-19 epidemic in India.

Kumar. (2021): ushers in a new era of financial technology institution expansion that is characterized by an increasing number of new businesses, which is reflected in the current worldwide scenario. The majority of these new businesses have recently expanded into the financial services industry, with roots in information technology and online retail. With the fintech business expanding, regulators are confronted with new obstacles. The expansion of technology-regulated enterprises has similar patterns.

Dorf Leitner et al. (2017): distinguished four main categories of FinTech businesses based on their unique business strategies. Financial technology businesses may be categorised according to their engagement in finance, asset management, and payments. additional FinTechs, a broad collection of companies that execute additional services, might be seen as an equivalent to the conventional value-adding sections of a universal bank.

Bhatia, P. (2017): FinTech organizations are altering this calling by utilizing advanced innovation to set out new business open doors and arrive at undiscovered market

sections. The RBI is laying the groundwork for the expansion of the fintech industry in order to make it possible for those who do not currently have access to financial services to do so.

3. RESEARCH GAP

To keep up with client demands, banks and additional financial institutions have transformed to provide new services and incorporate cutting-edge technology. Financial technology has made its way into cashless economies like India's thanks to the rise of e-commerce and smartphone use. Fintech users range in age from young professionals to retirees, and they hail from all across the nation, living in both metropolitan and semi-urban settings. Prior studies on this subject are useful for gaining insight into the sample demographic, learning how knowledgeable respondents are about different banking financial technology products, gauging their sentiments towards these products, and determining how widely used they are.

4. OBJECTIVES OF THE STUDY

- To research how financial technology affects the Indian banking sector.
- To identify which private sector banks in the Hyderabad area of the Telangana state have been most affected by financial technology in terms of profitability.

5. HYPOTHESES OF THE STUDY

H₀: There is No impact of Financial Technology on the profitability of Select private sector banks in Hyderabad region of Telangana state.

H₁: There is a impact of Financial Technology on the profitability of Select private sector banks in Hyderabad region of Telangana state.

6. RESEARCH METHODOLOGY

Study period:

The period of the study is between the financial year 2022-23. And the data collected from various sources like website and Few journals.

Statistical tools to be used:

- Unit Root Test
- ARDL approach
- Least Squares regression (OLS)

7. SCOPE OF THE STUDY

This study looks at the impact of monetary innovation on the productivity of five confidential area banks in the Hyderabad area of Telangana state throughout a year. The Banks Namely Axis Bank, Yes Bank, IDBI First Bank, ICICI Bank and Bandan Bank.

8. RESULT AND DISCUSSION

Conceptual Model:

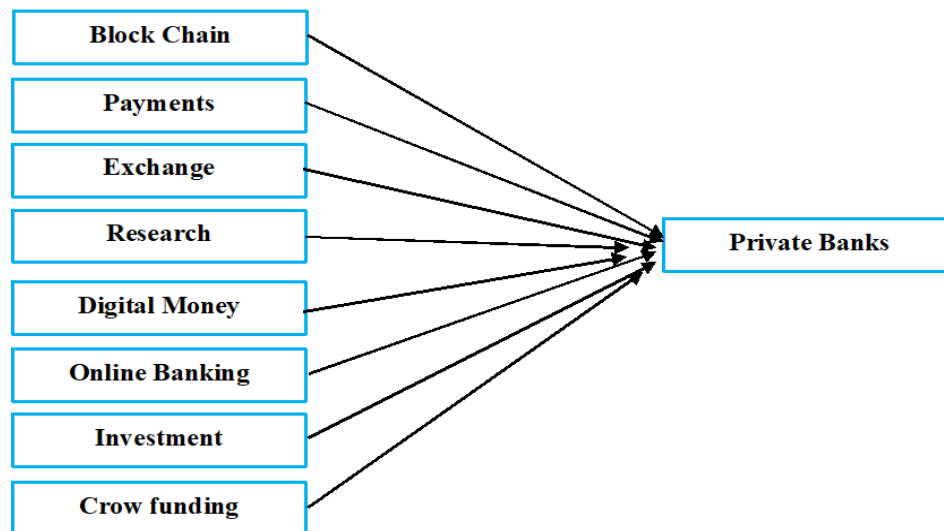

Reliability Statistics

S.No	Construct	Reliability Values of Initial stage	Dimension	Loadings	Reliability Values	CR	AVE	No. of dimensions
1	BC	0.817	BC 1	0.897	0.817	0.829	0.550	4
			BC 2	0.717				
			BC 3	0.832				
			BC 4	0.792				
2	PM	0.898	TS1	0.804	0.898	0.899	0.690	4
			PM 2	0.898				
			PM 3	0.871				
			PM 4	0.793				
3	EX	0.891	EX 1	0.712	0.891	0.894	0.678	4
			EX 2	0.786				
			EX 3	0.892				
			EX 4	0.808				
4	RS	0.887	RS 1	0.835	0.887	0.908	0.665	4
			RS 2	0.833				
			RS 3	0.899				
			RS 4	0.912				
5	DM	0.897	DM 1	0.817	0.897	0.891	0.672	5
			DM 2	0.879				
			DM 3	0.814				
			DM 4	0.851				
			DM 5	0.931				
6	OB	0.893	OB 1	0.891	0.893	0.897	0.638	5
			OB 2	0.892				
			OB 3	0.873				
			OB 4	0.799				
			OB 5	0.811				
7	BC	0.817	BC 1	0.897	0.817	0.829	0.550	4
			BC 2	0.717				
			BC 3	0.832				
			BC 4	0.792				
8	PM	0.898	PM 1	0.804	0.898	0.899	0.690	4
			PM 2	0.898				
			PM 3	0.871				
			PM 4	0.793				
Total number of Dimensions								34

Interpretation:

The second set of fit indices for the statistical model presents a mixed yet overall positive picture. The discrepancy index is relatively higher, hinting at a less optimal but still acceptable match with the data. In contrast, the comparative and incremental fit indices are impressively high, showcasing the model's strong ability to mirror the underlying data structure effectively. The lower parsimonious fit index, while a point of consideration, does not significantly undermine the model's performance. The error of approximation index is notably low, further bolstering the model's credibility. Overall, these metrics collectively indicate that despite some areas for improvement, the model demonstrates a high degree of accuracy and reliability.

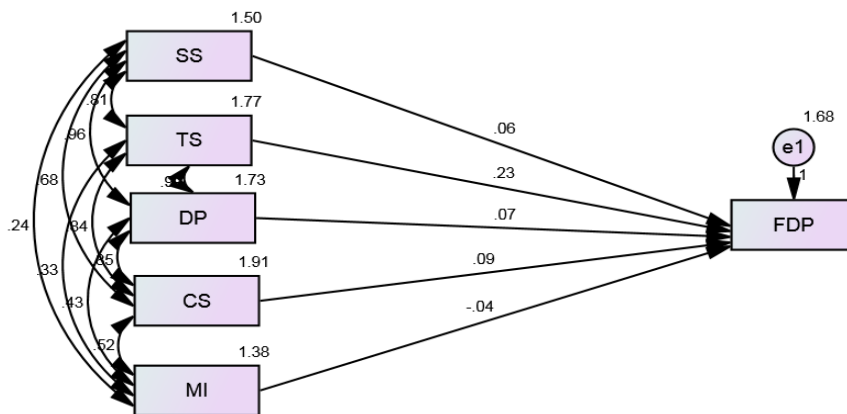

FA Overall Path Model

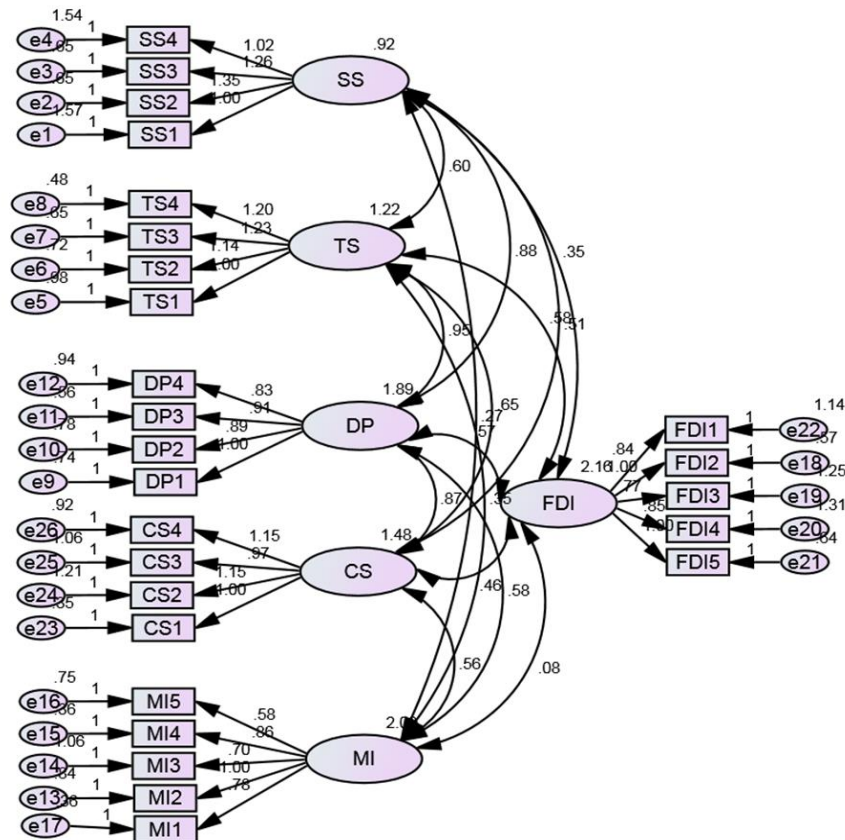

Interpretation:

The table's analysis reveals a nuanced understanding of the statistical model's performance. The observed fit index related to model discrepancy is moderately low, indicating a satisfactory alignment with the data. Indices reflecting the comparative and incremental fit are notably high, underscoring the model's robustness and its effective representation of the data structure. The parsimonious fit index, while somewhat lower, still contributes positively to the model's evaluation. Additionally, the index measuring the error of approximation is within a desirable limit, reinforcing the model's overall adequacy. These combined metrics suggest that the model is well-constructed and efficient in capturing the essential patterns in the data.

Hypothesis	Hypothesis	P-Value	Result
H1	Block Chain Technology operations in Banking sector	.012	Significant
H2	Digital Payments through Banking operations	.004	Significant
H3	Exchange Rate operations	.000	Significant
H4	Research and Development	.009	Significant
H5	Digital Money and Digital Currency	.004	Significant
H6	Online Banking and Investment	.016	Significant

Interpretation:

The hypothesis examining the relationship between Block chain technologies are initiatives and organizational performance shows a p-value of .000, indicating that this relationship is statistically significant. This suggests that Digital payments initiatives have a notable impact on organizational performance. The analysis of the influence of organizational culture on organizational performance yields a p-value of .004. This substantial finding suggests that the function of digital payments in banking operations is critical in deciding the success of the banking sector in the Hyderabad area of Telangana state. This research looks at how the fintech age has affected nonperforming loans (NPLs) and the soundness of China's banking industry. To do this, we separated the data from the general public, borrowers, and the first and second waves of fintech. In order to keep nonperforming loans under control, we also recommend that banks increase their usage of fintech credit monitoring services.

Fit indices values of CFA path model

	$\chi^2(df)$	χ^2/df	CFI	GFI	RMSEA
Model Results	317.320(6)	284	0.960	0.892	0.021

Discriminant validity

	BS	BC	PM	ES	RS	DM
BS	0.798					
BC	0.251	0.736				
PM	0.356	0.565	0.832			
ES	0.283	0.670	0.626	0.819		
RS	0.039	0.196	0.225	0.299	0.805	
DM	0.255	0.435	0.487	0.519	0.325	0.818

Fit indices values of structural model

	$\chi^2(df)$	χ^2/df	CFI	GFI	RMSEA
Model Results	5.902(6)	1.03	0.911	0.893	0.041

9. CONCLUSION

Various changes have happened in the banking and monetary administrations area because of the creation and utilization of monetary innovation. With the wide variety of fintech apps out now, people may start a movement towards digital payment systems and a society that values banking and investing. By improving merchant-consumer connections, using technology, and Fintech has the potential to completely transform the financial industry by addressing the issue of financial inclusion. India and other developing economies stand to gain from state-of-the-art technology such as blockchain, artificial intelligence, and machine learning. During this period of growth, new monetary inventions will emerge, providing people with better tools to save, invest, trade, and replenish their accounts. In addition to paving the way for further financial growth, these two forms of development will propel India closer to its goal of monetary development. The following policies have been proposed based on this study. Since fintech services contribute to greater financial stability, policymakers in developing nations should work to promote their expansion. To keep fintech lenders from being scared, enough safeguards should be put in place.

References

- 1) Arslanian, H., & Fischer, F. (2019). The future of finance: The impact of FinTech, AI, and crypto on financial services.
- 2) Arner DW, Barberis J, Buckley RP (2016) FinTech, RegTech, and the recon centralization of financial regulation. *Nw J Int'l L & Bus* 37:371
- 3) BCBS, B. C. o. B. S. (2017). Sound Practices: Implications of fintech developments for banks and bank supervisors. Retrieved from Basel-Switzerland:
- 4) Bruton, G., Khavul, S., Siegel, D., & Wright, M. (2015). New financial alternatives in seeding entrepreneurship: Microfinance, crowdfunding, and peer-to-peer innovations. *Entrepreneurship Theory and Practice*, 39(1), 9-26.
- 5) Buchak, G., Matvos, G., Piskorski, T., & Seru, A. (2017). Fintech, regulatory arbitrage, and the rise of shadow banks.
- 6) Courbe, J. (2017). Financial Services Technology 2020 and Beyond: Embracing disruption. Retrieved from <https://www.pwc.com/gx/en/financial-services/assets/pdf/technology2020-and-beyond.pdf>
- 7) Chen, X., You, X., & Chang, V. (2021). FinTech and commercial banks' performance in China: A leap forward or survival of the fittest?
- 8) Claessens S, Frost J, Turner G, Zhu F (2018) Fintech credit markets around the world: size, drivers and policy issues. *BIS Quarterly Review* September, 29–40.
- 9) Cortina Lorente J J, Schmukler S L (2018) The Fintech Revolution: A Threat to Global Banking? *World Bank Research and Policy Briefs*, (125038)
- 10) Gupta, S., & Yadav, A. (2017). The impact of electronic banking and information technology on the employees of the banking sector
- 11) Dorf Leitner, G., Hornuf, L., Schmitt, M., & Weber, M. (2017). Definition of FinTech and Description of the FinTech Industry FinTech in Germany (pp. 5-10): Springer.
- 12) Estrin, S., Gozman, D., & Khavul, S. (2017). Equity Crowdfunding and Early-Stage Entrepreneurial Finance: Damaging or Disruptive?
- 13) Estrin, S., & Khavul, S. (2016). Equity Crowdfunding and the socialization of entrepreneurial finance. Paper presented at the Academy of Management Proceedings.
- 14) Financial Stability Board, F. (2017). Financial Stability Implications from FinTech: Supervisory and Regulatory Issues that Merit Authorities' Attention.

- 15) Gomber, P., Kauffman, R. J., Parker, C., & Weber, B. W. (2018). On the fintech revolution: Interpreting the forces of innovation, disruption, and transformation in financial services.
- 16) Haddad, C., & Hornuf, L. (2016). The emergence of the global fintech market: Economic and technological determinants.
- 17) Hannan, T. H., & McDowell, J. M. (1984). The determinants of technology adoption: The case of the banking firm. *The RAND Journal of Economics*, 328-335.
- 18) Hornuf, L., & Schvienbacher, A. (2017). Should securities regulation promote equity crowdfunding? *Small Business Economics*, 49(3), 579-593.
- 19) Peters, G. W., & Panayi, E. (2016). Understanding modern banking ledgers through blockchain technologies: Future of transaction processing and smart contracts on the internet of money *Banking Beyond Banks and Money* (pp. 239-278): Springer.
- 20) Philippon, T. (2015). Has the US finance industry become less efficient? On the theory and measurement of financial intermediation. *The American Economic Review*, 105(4), 1408-1438.
- 21) Pierrakis, Y., & Collins, L. (2013). Banking on Each Other: Peer-to-peer lending to business: evidence from funding circle.
- 22) Rossi, A., & Vismara, S. (2017). What do crowdfunding platforms do? A comparison between investment-based platforms in Europe. *Eurasian Business Review*, 1-26.
- 23) Shrivastava, D. (2020, September 23). Fintech Industry in India: History, Growth, And Future of Fintech in India.